

Gas-actuated thermometer with switch contacts

Stainless steel version

Model TGS73

WIKA data sheet TV 27.01



for further approvals
see page 9

Applications

- Control and regulation of industrial processes
- Monitoring of plants and switching of circuits
- Universally suitable for machine building, plant, tank, equipment manufacturing and food industry
- Temperature measurement without medium contact
- Mounting in instrument boards, control cabinets, control panels

Special features

- Instruments meet the highest standards of measurement technology
- Case and stem from stainless steel
- For external mounting on pipes and tanks
- Instruments with inductive contacts for use in hazardous areas
- Instruments with contacts for PLC applications

Description

Wherever the process temperature has to be indicated on-site or in places that are difficult to access and, at the same time, circuits need to be switched, the gas-actuated thermometer with switch contacts finds its use.

Due to the wide variety of possible designs, the model TGS73 gas-actuated thermometers can be perfectly adapted to any process connection or location. With the adjustable stem and dial version, the case can be adjusted precisely to the desired viewing angle.

With the contact bulb version (without direct contact with the medium), the temperature can be measured and controlled even when the pipe diameter is extremely small. The contact bulb is intended for external mounting on pipes and tanks. When mounting this thermometer version, it must be ensured that the contact bulb is in contact with the measuring point over its complete length.



Fig. top: with capillary

Fig. bottom: Back mount

Switch contacts (electrical alarm contacts) make or break circuits dependent upon the pointer position of the indicating measuring instrument. The switch contacts are adjustable over the full measuring range. The instrument pointer (actual value pointer) moves freely across the entire scale range, independent of the setting. The set pointer can be adjusted via the window using a removable adjustment key (mounted on the terminal box). Switch contacts consisting of several contacts can also be set to a single set point. Contact actuation is made when the actual value pointer travels beyond or below the desired set point.

As switch contacts, magnetic snap-action contacts, inductive contacts and electronic contacts are available. Inductive contacts can be used in hazardous areas. For triggering programmable logic controllers (PLC), electronic contacts can be used.

Specifications

Gas-actuated thermometer, model TGS73	
Measuring element	Gas-pressure inert gas filling, physiologically safe
Nominal size in mm	<ul style="list-style-type: none"> ■ 100 ■ 160
Instrument version	<ul style="list-style-type: none"> ■ Back mount (axial) ■ Lower mount (radial) ■ Back mount, adjustable stem and dial ■ Version with capillary
Connection designs	<ul style="list-style-type: none"> ■ S, Standard (threaded connection) ¹⁾ ■ 1, Plain stem (without thread) ■ 2, Male nut ■ 3, Union nut ■ 4, Compression fitting (sliding on stem) ■ 5, Union nut and loose threaded connection ■ 6, Compression fitting (can be adjusted on either capillary or spiral protective sleeve) ■ 7, Compression fitting at the case
Unit (scale range)	°C Option: <ul style="list-style-type: none"> ■ °F ■ °C/°F (dual scale)
Process connection	<ul style="list-style-type: none"> ■ Plain, without thread ■ G ½ B ■ ½ NPT ■ G ½ female ■ ½ NPT female ■ M20 x 1.5 ■ M24 x 1.5 female others on request
Accuracy class per DIN 16196	Class 1 at 23 °C ±10 °C ambient temperature
Rated operating ranges and conditions	DIN 16196 (EN 13190)
Stem diameter	8 mm Option: <ul style="list-style-type: none"> ■ 6 mm ■ 10 mm ■ 12 mm others on request
Working range	
Continuous load (1 year)	Measuring range (DIN 16196)
Short time (max. 24 h)	Scale range (DIN 16196)
Window	Laminated safety glass
Contact bulb	120 x 22 x 12 mm
Adjustable stem and dial	Swivelling 90° 360° rotatable
Capillary	Ø 2 mm Minimum curve radius: 6 mm Length to customer specification Option: Armoured coating for capillary (Ø 7 mm spiral protective sleeve, flexible or PVC-coated)
Mounting types for instruments with capillary	<ul style="list-style-type: none"> ■ Surface mounting flange, stainless steel ■ Instrument mounting bracket, aluminium die-casting ■ Panel mounting flange, stainless steel
Dampening (option)	<ul style="list-style-type: none"> ■ With liquid dampening ■ With food-compatible liquid dampening

1) Not applicable to instruments with capillary

Gas-actuated thermometer, model TGS73	
Wetted materials	
Stem, process connection	Stainless steel 316SS
Non-wetted materials	
Case, bayonet ring	Stainless steel 304SS (option: stainless steel 316SS)
Contact bulb, capillary	Stainless steel 316SS
Dial	Aluminium, white, black lettering
Pointer	Aluminium, black, adjustable pointer
Ingress protection per IEC/EN 60529	IP65 Option: IP66
Permissible temperatures ²⁾	
Ambient (at the case)	-20 ... +60 °C [-4 ... +140 °F] without/with liquid dampening
Storage and transport	
Without liquid dampening	-50 ... +70 °C [-58 ... +158 °F]
With liquid dampening	-40 ... +70 °C [-40 ... +158 °F]
Permissible operating pressure at the stem	max. 25 bar, static
Electrical connection	Cable socket PA 6, black According to VDE 0110 insulation group C/250 V Cable gland M20 x 1.5 Strain relief 6 screw terminals + PE for conductor cross-section 2.5 mm ² Dimensions see page 12 others on request

2) For hazardous areas, the permissible temperatures of the contact model 831 shall apply exclusively (for permissible temperature ranges see page 5). These must not be exceeded at the instrument either (for details see operating instructions). If necessary, measures for cooling (e.g. measuring point insulation) have to be taken.

Scale range, measuring range, error limit (DIN 16196)

Scale graduation per WIKA standard

Scale range in °C	Measuring range in °C ³⁾	Scale spacing in °C	Error limit in °C
-80 ... +60	-60 ... +40	2	3.0
-60 ... +40	-50 ... +30	1	1.5
-40 ... +60	-30 ... +50	1	1.5
-30 ... +50	-20 ... +40	1	1.5
-20 ... +60	-10 ... +50	1	1.5
-20 ... +80	-10 ... +70	1	1.5
-20 ... +120	0 ... 100	2	3.0
-20 ... +140	0 ... 120	2	3.0
0 ... 60	10 ... 50	1	1.5
0 ... 80	10 ... 70	1	1.5
0 ... 100	10 ... 90	1	1.5
0 ... 120	10 ... 110	2	3.0
0 ... 160	20 ... 140	2	3.0
0 ... 200	20 ... 180	2	3.0
0 ... 250	30 ... 220	5	3.75
0 ... 300	30 ... 270	5	7.5
0 ... 400	50 ... 350	5	7.5
0 ... 500	50 ... 450	5	7.5
0 ... 600	100 ... 500	10	15.0
0 ... 700	100 ... 600	10	15.0

3) The measuring range is indicated on the dial by two triangular marks. Only within this range is the stated error limit valid per DIN 16196.

Please indicate switch points!

Unless otherwise specified, the instrument will be delivered with the adjustable switching points factory-set as follows:

- Single contact Start of measuring range
- Double contact Start and end of the measuring range

Switch contacts

Magnetic snap-action contact model 821

- No control unit and no power supply required
- Direct switching up to 250 V, 1 A
- Up to 4 switch contacts per measuring instrument

Inductive contact model 831

- Suitable for use in hazardous areas with corresponding control unit (model 904.xx)
- Long service life due to non-contact sensor
- Low influence on the indication accuracy
- Fail-safe switching at high switching frequency
- Insensitive to corrosion
- Also available in safety version
- Up to 3 switch contacts per measuring instrument

Electronic contact model 830 E

- For direct triggering of a programmable logic controller (PLC)
- 2-wire system (option: 3-wire system)
- Long service life due to non-contact sensor
- Low influence on the indication accuracy
- Fail-safe switching at high switching frequency
- Insensitive to corrosion
- Up to 3 switch contacts per measuring instrument

Switching function

The switching function of the switch is indicated by index 1, 2 or 3.

Model 8xx.1: Normally open (clockwise pointer motion)

Model 8xx.2: Normally closed (clockwise pointer motion)

Model 8xx.3: Change-over; one contact breaks and one contact makes simultaneously when pointer reaches set point

Please indicate switch points!

Unless otherwise specified, the instrument will be delivered with the adjustable switching points factory-set as follows:

- Single contact Start of measuring range
- Double contact Start and end of the measuring range
- Triple contact Start, middle and end of the measuring range

Note

For magnetic snap-action contacts, it does not make sense to test the display, around the set limit values, in the range $\pm 5\%$ of the measuring span, because the magnet has an influence on the indication accuracy.

For further information on switch contacts, see data sheet AC 08.01

Other versions

- Contact model 821 with separate circuits
- Contact model 821 as change-over contact (break or make simultaneously at the set point)
- Contact model 821 with cable break monitoring (parallel resistance 47 k Ω and 100 k Ω)
- Contact materials for contact model 821: Platinum-iridium alloy and gold-silver alloy
- Contacts fixed, without contact adjustment lock
- Contact adjustment lock leaded
- Contact adjustment key fixed
- Connector (instead of cable or cable socket)

Specifications for instruments with magnetic snap-action contact model 821

The recommended setting range of the contacts is 25 ... 75 % of the scale (0 ... 100 % on request).

Contact material (standard): Silver-nickel, gold-plated

Setting of contacts to identical set point

The recommended minimum clearance between two contacts is 20 % of the scale range.

The switch hysteresis is 2 ... 5 % (typical).

Characteristics	Unfilled instruments	Filled instruments
	Resistive load	Resistive load
	Switch version "L"	Switch version "L"
Rated operating voltage U_{eff}	$\leq 250 \text{ V}$	$\leq 250 \text{ V}$
Rated operating current		
Switch-on current	$\leq 0.5 \text{ A}$	$\leq 0.5 \text{ A}$
Switch-off current	$\leq 0.5 \text{ A}$	$\leq 0.5 \text{ A}$
Continuous current	$\leq 0.3 \text{ A}$	$\leq 0.3 \text{ A}$
Switching power	$\leq 30 \text{ W} / \leq 50 \text{ VA}$	$\leq 20 \text{ W} / \leq 20 \text{ VA}$

Recommended contact load with resistive and inductive loads

Operating voltage	Unfilled instruments			Filled instruments		
	Resistive load		Inductive load	Resistive load		Inductive load
	Direct current	Alternating current	$\cos \phi > 0.7$	Direct current	Alternating current	$\cos \phi > 0.7$
DC 220 V / AC 230 V	100 mA	120 mA	65 mA	65 mA	90 mA	40 mA
DC 110 V / AC 110 V	200 mA	240 mA	130 mA	130 mA	180 mA	85 mA
DC 48 V / AC 48 V	300 mA	450 mA	200 mA	190 mA	330 mA	130 mA
DC 24 V / AC 24 V	400 mA	600 mA	250 mA	250 mA	450 mA	150 mA

Specifications for instruments with inductive contact model 831

The recommended setting range of the contacts is 10 ... 90 % of the scale (0 ... 100 % on request).

Setting of contacts to identical set point

Up to 2 contacts can be set to an identical set point. For a version with 3 contacts this is not possible. The left (no. 1) or right (no. 3) contact may not be set to the same set point as the other 2 contacts. The required displacement is approx. 30°, optionally to the right or to the left.

Available contact versions

- 831-N
- 831-SN, safety version ¹⁾
- 831-S1N, safety version ¹⁾, inverted signal

¹⁾ only operate with a corresponding isolating amplifier (model 904.3x)

Permissible temperature range

T6	T5 ... T1	T135°C
-20 ... +60 °C	-20 ... +70 °C	-20 ... +70 °C

For further information on hazardous areas, see operating instructions.

Associated isolating amplifiers and control units

Model	Version	Ex version
904.28 KFA6 - SR2 - Ex1.W	1 contact	yes
904.29 KFA6 - SR2 - Ex2.W	2 contacts	yes
904.30 KHA6 - SH - Ex1	1 contact	yes - safety equipment
904.33 KFD2-SH-Ex1	1 contact	yes - safety equipment
904.25 MSR 010-I	1 contact	no
904.26 MSR 020-I	2 contacts	no
904.27 MSR 011-I	Two-point control	no

Specifications for instruments with electronic contact model 830 E

The recommended setting range of the contacts is 10 ... 90 % of the scale (0 ... 100 % on request).

Setting of contacts to identical set point

Up to 2 contacts can be set to an identical set point. For a version with 3 contacts this is not possible.

The left (no. 1) or right (no. 3) contact may not be set to the same set point as the other 2 contacts.

The required displacement is approx. 30°, optionally to the right or to the left.

Characteristics	
Contact version	Normally open, normally closed
Type of output	PNP transistor
Operating voltage	DC 10 ... 30 V
Residual ripple	max. 10 %
No-load current	≤ 10 mA
Switching current	≤ 100 mA
Residual current	≤ 100 μA
Voltage drop (with $I_{max.}$)	≤ 0.7 V
Reverse polarity protection	Conditional U_B (the switched output 3 or 4 must never be set directly to minus)
Anti-inductive protection	1 kV, 0.1 ms, 1 kΩ
Oscillator frequency	approx. 1,000 kHz
EMC	per EN 60947-5-2



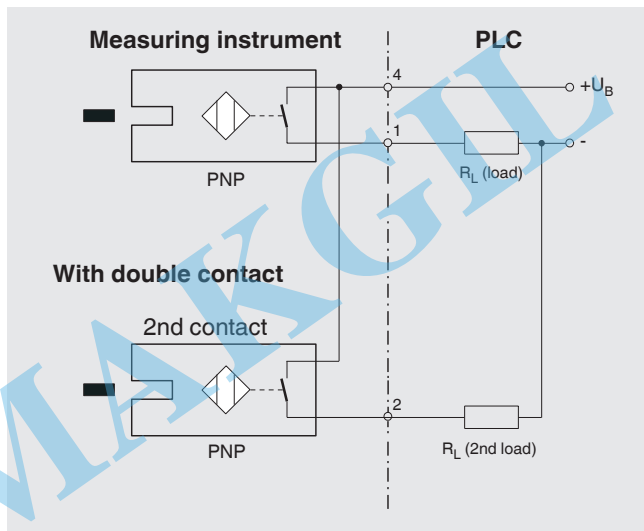



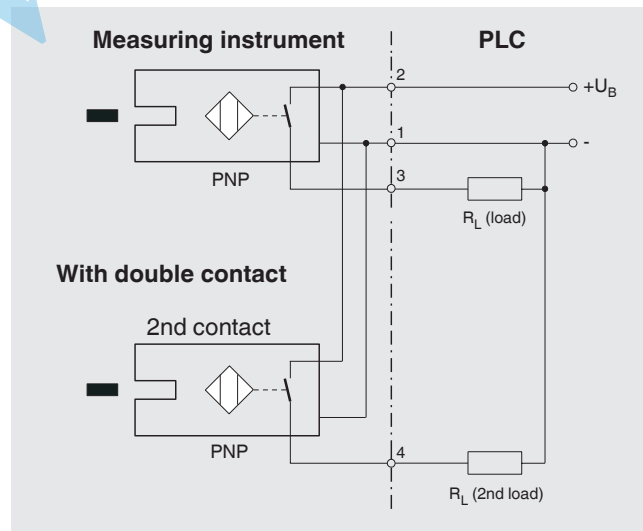

2-wire system (standard)



3-wire system



Approvals

Logo	Description	Country
 	EU declaration of conformity <ul style="list-style-type: none"> ■ EMC directive ■ Low voltage directive ■ RoHS directive ■ ATEX directive (option) ¹⁾ Hazardous areas - Ex ia Zone 1 gas [II 2G Ex ia IIC T6/T5/T4 * Gb] Zone 21 dust [II 2D Ex ia IIIB T85°C/T95°C/T100°C/T135°C * Db]	European Union
	IECEx (option) ¹⁾ Hazardous areas - Ex ia Zone 1 gas [Ex ia IIC T6/T5/T4 * Gb] Zone 21 dust [Ex ia IIIB T85°C/T95°C/T100°C/T135°C * Db]	International
	EAC (option) <ul style="list-style-type: none"> ■ Import certificate ■ EMC directive ■ Hazardous areas ¹⁾ 	Eurasian Economic Community
	GOST (option) Metrology, measurement technology	Russia
	KazInMetr (option) Metrology, measurement technology	Kazakhstan
-	MTSCHS (option) Permission for commissioning	Kazakhstan
	BelGIM (option) Metrology, measurement technology	Belarus
	Uzstandard (option) Metrology, measurement technology	Uzbekistan
-	CRN (option) Safety (e.g. electr. safety, overpressure, ...)	Canada

1) Only for instruments with inductive contact model 831

Certificates (option)

- 2.2 test report
- 3.1 inspection certificate with 3 test points (optionally with 5 test points)
- DKD/DAkkS calibration certificate

Approvals and certificates, see website

Connection designs

Standard design (male threaded connection) ¹⁾

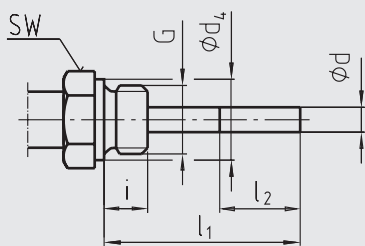

Standard insertion length $l_1 = 63, 100, 160, 200, 250$ mm

Nominal size	Process connection		Dimensions in mm		
	NS	G	i	SW	d_4
100, 160	G 1/2 B	14	27	26	8
	G 3/4 B	16	32	32	8
	1/2 NPT	19	22	-	8
	3/4 NPT	20	30	-	8

1) Not applicable to instruments with capillary

Design 1, plain stem (without thread)

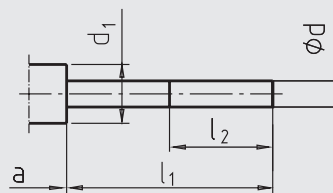

Standard insertion length $l_1 = 100, 140, 200, 240, 290$ mm

Nominal size	Dimensions in mm			
	NS	$d_1^{2)}$	$\varnothing d$	a for axial
100, 160	18	8	15	25

2) Not applicable to version with capillary

3073050.05

Design 2, male nut

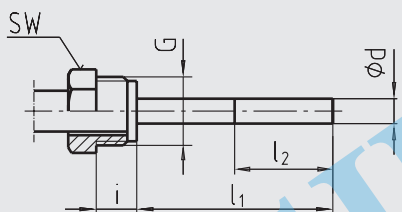

Standard insertion length $l_1 = 80, 140, 180, 230$ mm

Nominal size	Process connection		Dimensions in mm	
	NS	G	i	SW
100, 160	G 1/2 B	20	27	8
	M20 x 1.5	15	22	8

Design 3, union nut

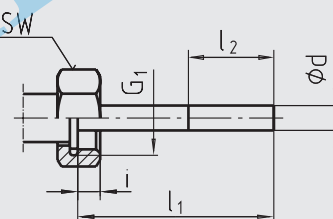

Standard insertion length $l_1 = 89, 126, 186, 226, 276$ mm

Nominal size	Process connection		Dimensions in mm	
	NS	G	i	SW
100, 160	G 1/2 B	8.5	27	8
	G 3/4 B	10.5	32	8
	M24 x 1.5	13.5	32	8

Design 4, compression fitting (sliding on stem)

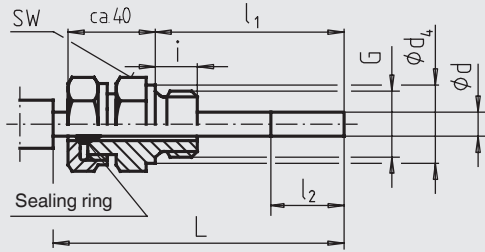

Insertion length l_1 = variable
 Length $L = l_1 + 40$ mm

Nominal size	Process connection		Dimensions in mm		
	G	i	SW	d_4	$\varnothing d$
100, 160	G 1/2 B	14	27	26	8
	G 3/4 B	16	32	32	8
	M18 x 1.5	12	24	23	8
	1/2 NPT	19	22	-	8
	3/4 NPT	20	30	-	8

Design 5, union nut and loose threaded connection

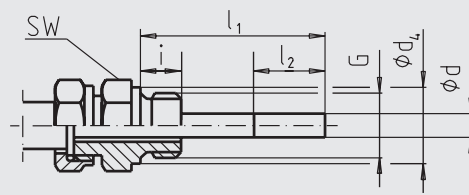

Standard insertion length $l_1 = 63, 100, 160, 200, 250$ mm

Nominal size	Process connection		Dimensions in mm		
	G	i	SW	d_4	$\varnothing d$
100, 160	G 1/2 B	14	27	26	8
	G 3/4 B	16	32	32	8
	M18 x 1.5	12	24	23	8
	1/2 NPT	19	22	-	8
	3/4 NPT	20	30	-	8

Option: Connection with union nut M24 x 1.5
 and loose threaded connection M18 x 1.5

Nominal size	Process connection		Dimensions in mm		
	G	i	SW	$\varnothing d_4$	$\varnothing d$
100, 160	M18 x 1.5	12	32	23	8

Design 6.1, compression fitting sliding on capillary (compression fitting is leak-proof)

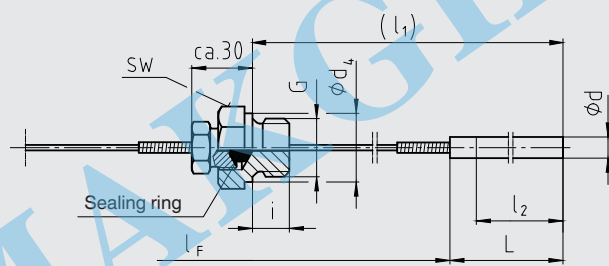

Insertion length l_1 = variable
 Probe length L: Standard 200 mm with $\varnothing d = 6$ mm
 Standard 170 mm with $\varnothing d = 8$ mm
 Standard 100 mm with $\varnothing d \geq 10$ mm

Nominal size	Process connection		Dimensions in mm		
	G	i	SW	d_4	$\varnothing d$
100, 160	G 1/2 B	14	27	26	8
	G 3/4 B	16	32	32	8
	1/2 NPT	19	22	-	8
	3/4 NPT	20	30	-	8

Design 6.2, compression fitting sliding on capillary with spiral protective sleeve (compression fitting is leak-proof)

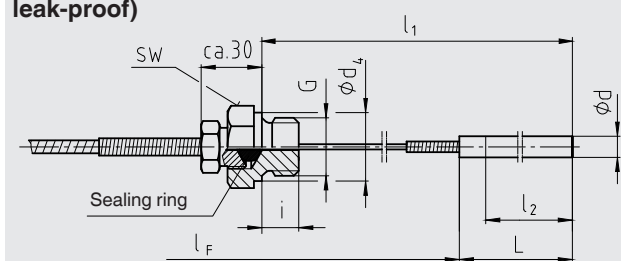

Insertion length l_1 : ≥ 300 mm with $\varnothing d = 6$ or 8 mm
 ≥ 200 mm with $\varnothing d \geq 10$ mm
 Probe length L: Standard 200 mm with $\varnothing d = 6$ mm
 Standard 170 mm with $\varnothing d = 8$ mm
 Standard 100 mm with $\varnothing d \geq 10$ mm

Nominal size	Process connection		Dimensions in mm		
	G	i	SW	d_4	$\varnothing d$
100, 160	G 1/2 B	14	27	26	8
	G 3/4 B	16	32	32	8
	1/2 NPT	19	22	-	8
	3/4 NPT	20	30	-	8

Design 6.3, compression fitting sliding on spiral protective sleeve (compression fitting is not leak-proof)

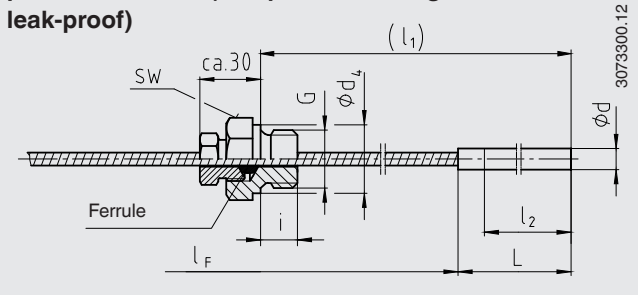

3073300.12

Insertion length l_1 = variable
 Probe length L: Standard 200 mm with $\varnothing d = 6$ mm
 Standard 170 mm with $\varnothing d = 8$ mm
 Standard 100 mm with $\varnothing d \geq 10$ mm

Nominal size	Process connection		Dimensions in mm		
	G	i	SW	d_4	$\varnothing d$
100, 160	G 1/2 B	14	27	26	8
	G 3/4 B	16	32	32	8
	1/2 NPT	19	22	-	8
	3/4 NPT	20	30	-	8

Design 7, compression fitting at the case

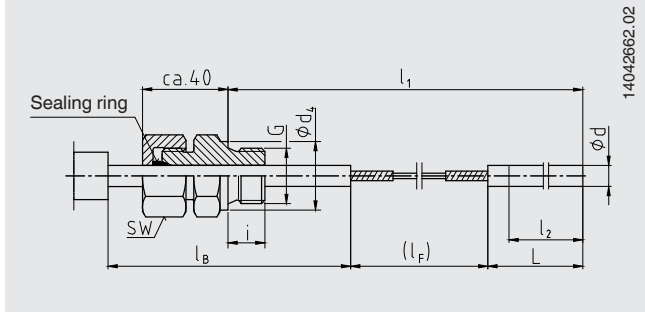

14042662.02

Insertion length l_1 : ≥ 400 mm
 Probe length L: Standard 200 mm with $\varnothing d = 6$ mm
 Standard 170 mm with $\varnothing d = 8$ mm
 Standard 100 mm with $\varnothing d \geq 10$ mm
 l_B = standard 100 mm (others on request)

Nominal size	Process connection		Dimensions in mm		
	G	i	SW	d_4	$\varnothing d$
100, 160	G 1/2 B	14	27	26	8
	G 3/4 B	16	32	32	8
	1/2 NPT	19	22	-	8
	3/4 NPT	20	30	-	8

Note for designs 6.1, 6.2, 6.3 and 7:

With some combinations, the active length l_2 can correspond to the probe length L.
 If an additional compression fitting is desired, the probe length L increases by at least 60 mm.

Legend:

- G Male thread
- G₁ Female thread
- i Thread length (incl. collar)
- a Distance to the case/articulated joint
- $\varnothing d_4$ Diameter of the sealing collar
- SW Spanner width
- $\varnothing d$ Stem diameter
- l_1 Insertion length
- l_2 Active length
- l_F Capillary length
- l_B Mounting shaft

Dimensions in mm

Cable socket

Contact model: 821

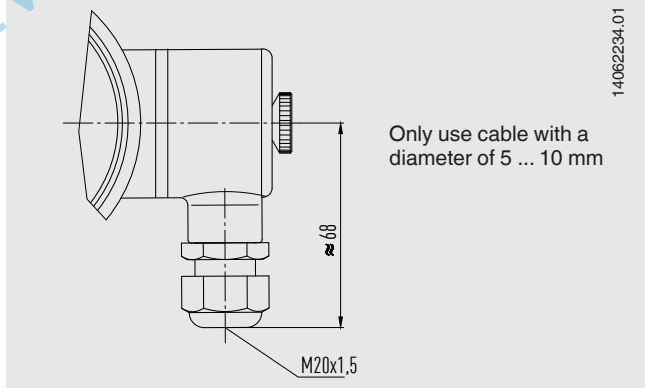

14062234.01

Contact models: 831 and 830 E

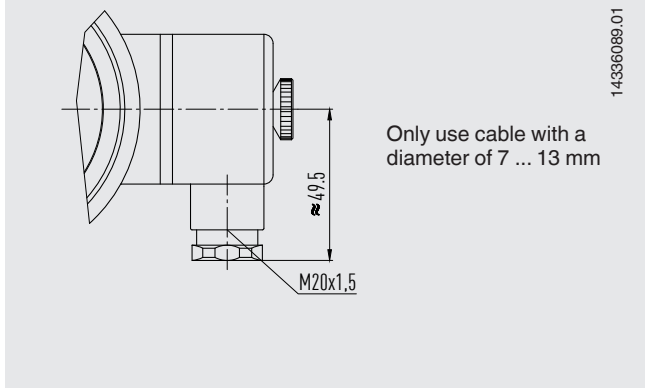

14336089.01

Back mount

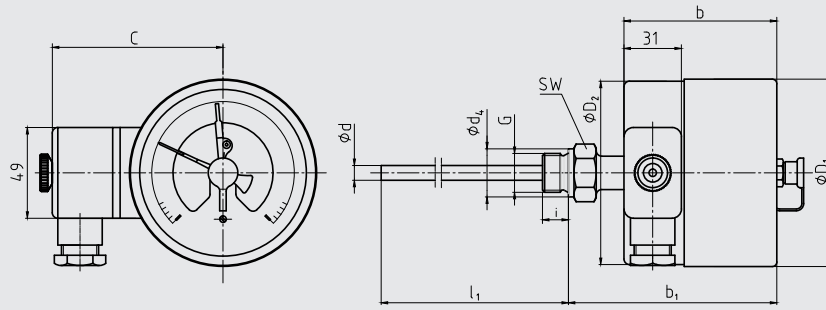

11442522.02

Lower mount

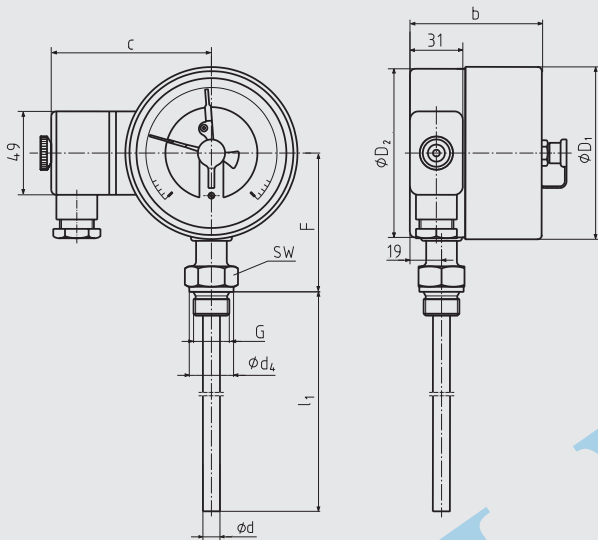

11442850.01

Back mount Adjustable stem and dial

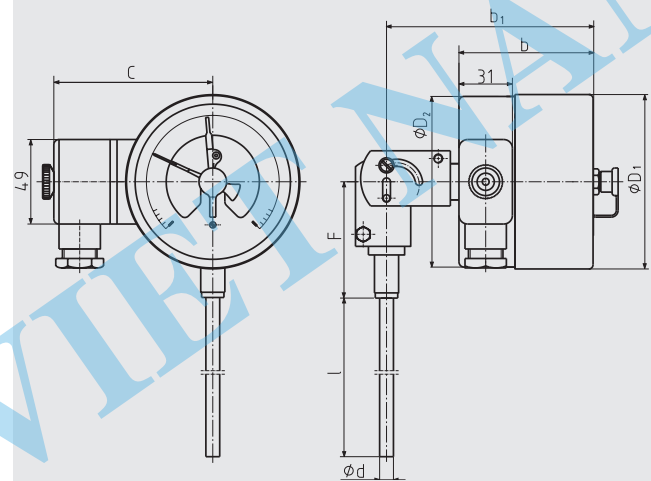

11443171.01

Back mount, lower mount

Nominal size	Dimensions in mm											Weight in kg
	Switch contact model 821 or 831											
	1- or 2-way		3-way									
NS	b	b ₁ ¹⁾	b	b ₁ ¹⁾	d	d ₄	D ₁	D ₂	F ¹⁾	G	SW	
100	88	121	-	-	8 ²⁾	26	101	99	83	G ½ B	27	1.3
160	88	121	96	129	8 ²⁾	26	161	159	113	G ½ B	27	1.5

Back mount, adjustable stem and dial

Nominal size	Dimensions in mm								Weight in kg
	Switch contact model 821 or 831								
	1- or 2-way		3-way						
NS	b	b ₁	b	b ₁	d	D ₁	D ₂	F	
100	88	131	-	-	8 ²⁾	101	99	68	
160	88	131	97	140	8 ²⁾	161	159	68	

1) With scale ranges ≥ 0 ... 300 °C the dimensions increase by 40 mm

2) Option: Stem diameter 6, 10, 12 mm

Dimensions in mm for instruments with capillary

Surface mounting flange

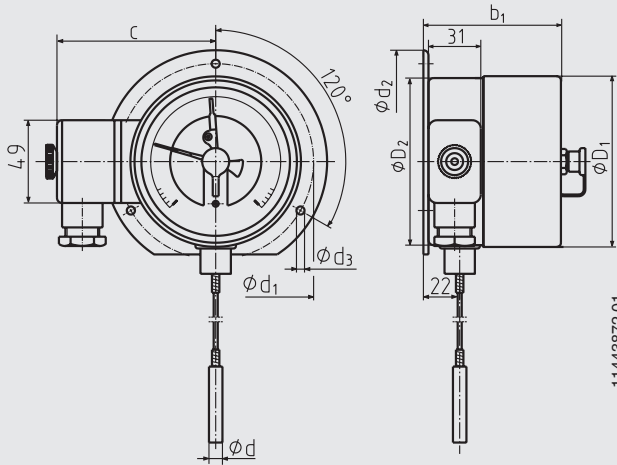

Instrument mounting bracket

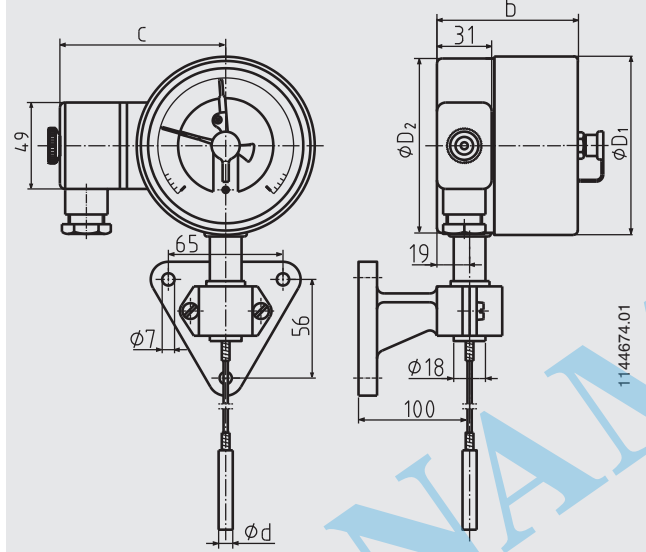

Instruments NS 100 with panel mounting flange

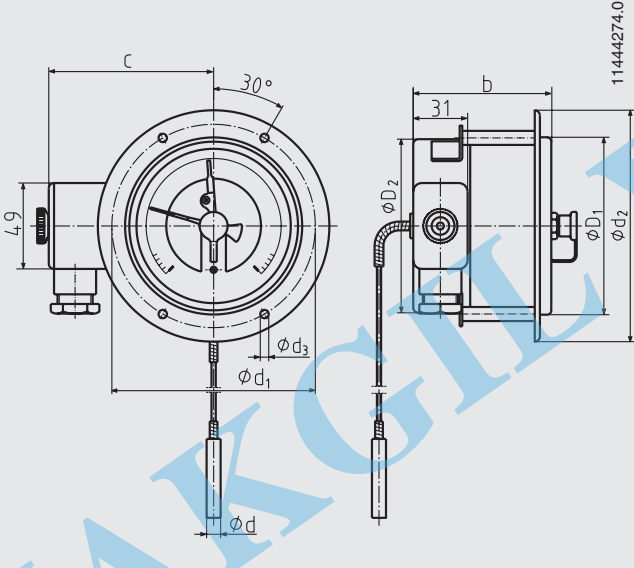

Instruments NS 160 with panel mounting flange

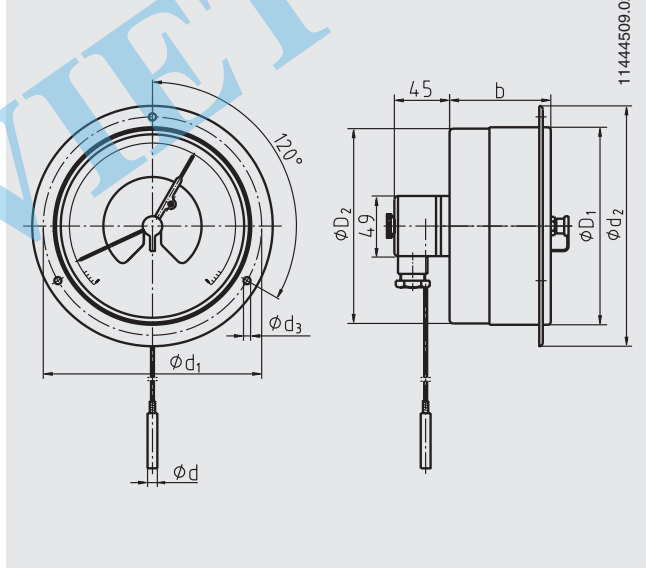

Nominal size	Dimensions in mm												Weight in kg
	Switch contact model 821 or 831												
	1- or 2-way		3-way		d	d ₁	d ₂	d ₃	D ₁	D ₂	D ₃	h	
NS	b	b ₁	b	b ₁	d	d ₁	d ₂	d ₃	D ₁	D ₂	D ₃	h	
100	88	91	-	-	8 ²⁾	116	132	4.8	101	99	107	107	1.6
160	88	91	97	100	8 ²⁾	178	196	5.8	161	159	166	172	2,0

2) Option: Stem diameter 6, 10, 12 mm

Dimensions in mm for instruments with contact bulb

Back mount

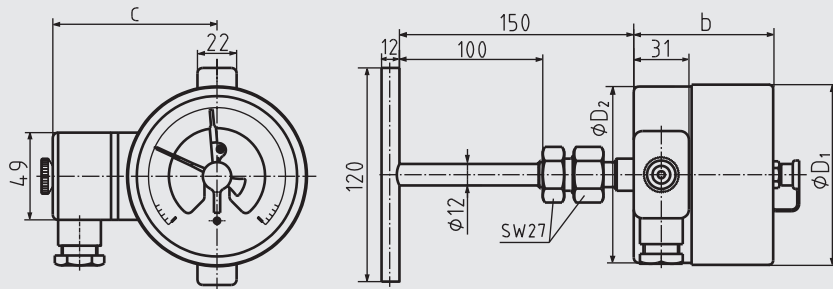

11443413.01

Lower mount

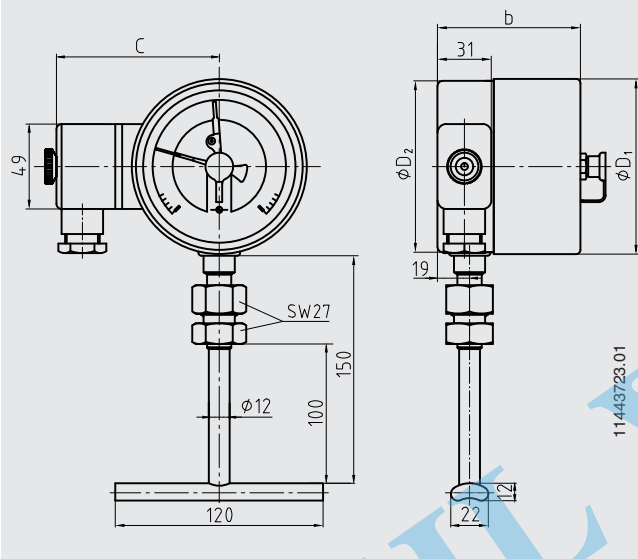

11443723.01

Back mount, adjustable stem and dial

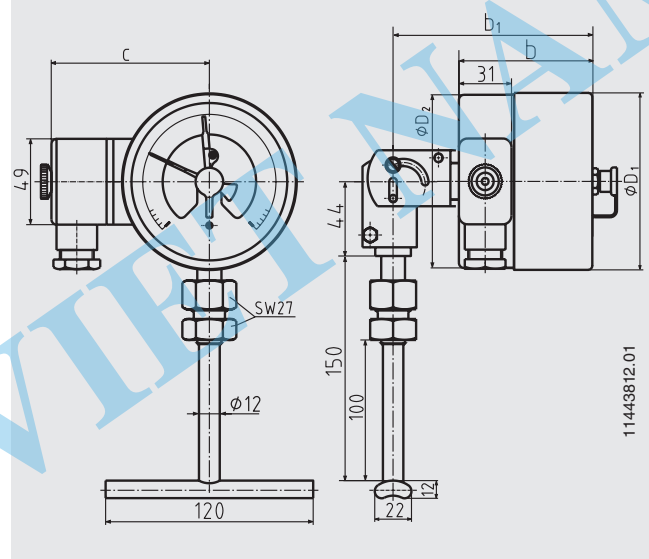

11443812.01

Connection location	Nominal size	Dimensions in mm							Weight in kg
		Switch contact model 821 or 831							
		1- or 2-way		3-way		D ₁	D ₂		
NS	b	b ₁	b	b ₁	D ₁	D ₂			
Back mount	100	88	-	-	-	101	99	1.0	
	160	88	-	97	-	161	159	1.1	
Lower mount	100	88	-	-	-	101	99	1.0	
	160	88	-	97	-	161	159	1.1	
Adjustable stem and dial	100	88	131	-	-	101	99	1.1	
	160	88	131	97	140	161	159	1.2	

Dimensions in mm for instruments with contact bulb and capillary

Surface mounting flange

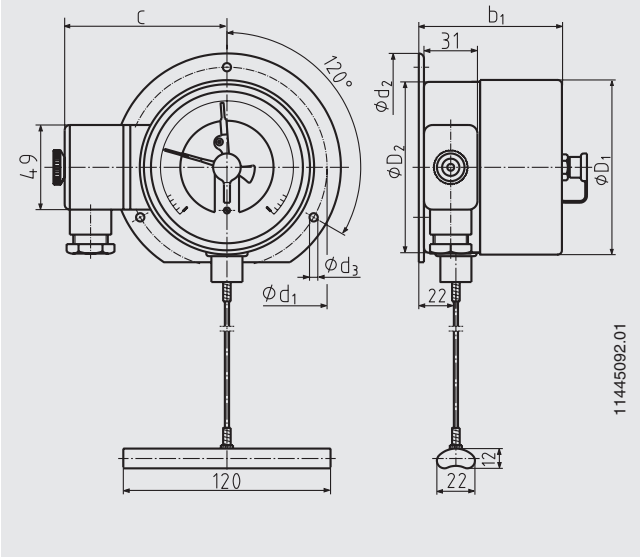

Instrument mounting bracket

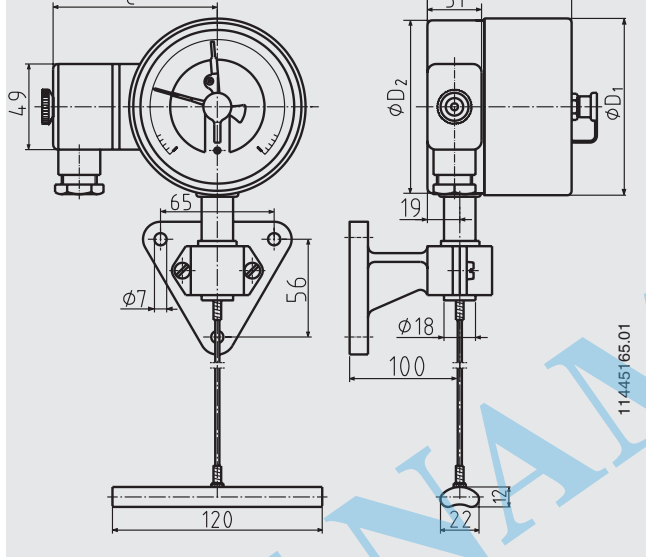

Instruments NS 100 with panel mounting flange

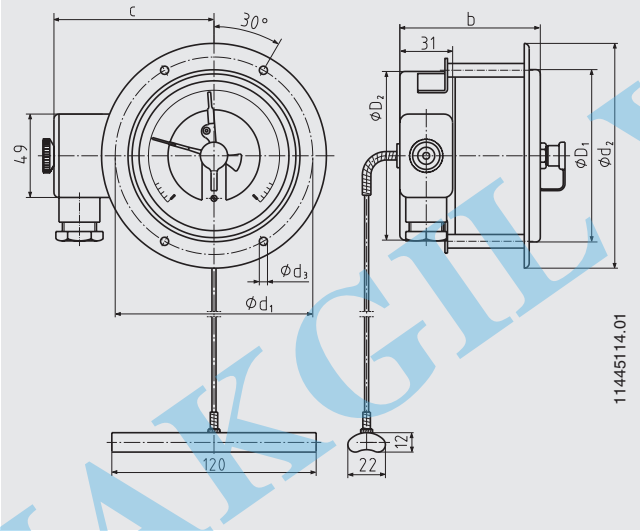

Instruments NS 160 with panel mounting flange

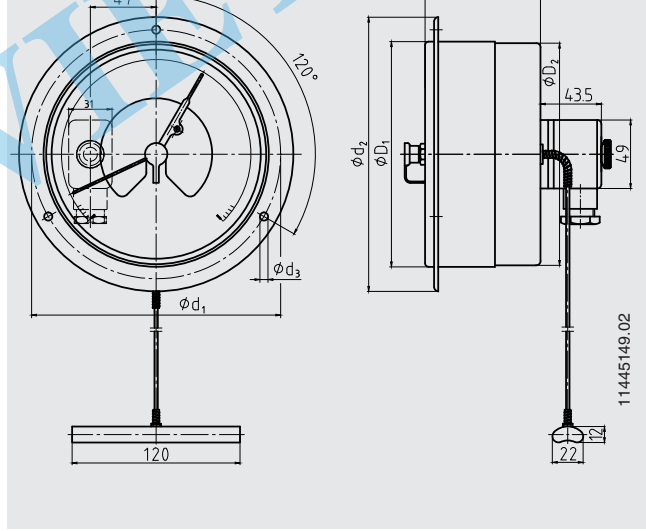

Nominal size	Dimensions in mm											Weight in kg
	Switch contact model 821 or 831				d ₁	d ₂	d ₃	D ₁	D ₂	D ₃	h	
	1- or 2-way		3-way									
NS	b	b ₁	b	b ₁	d ₁	d ₂	d ₃	D ₁	D ₂	D ₃	h	
100	88	91	-	-	116	132	4.8	101	99	107	107	1.6
160	88	91	97	100	178	196	5.8	161	159	166	172	2.0

Mounting instructions for contact bulb

General information

The contact bulb has been designed for mounting on pipes or tanks. When mounting this thermometer version, it must be ensured that the contact bulb is in contact with the measuring point over its complete length. The basic requirements to ensure a perfect measuring result is to retain good thermal contact between the contact bulb and the outside wall of the pipe or tank with minimal heat loss to the environment from the contact bulb and measuring point.

■ Mounting on pipes

The geometry of the contact bulb has been designed for pipes with external diameters between 20 and 160 mm. For fixing the contact bulb to the pipe, pipe clamps are sufficient. The contact bulb should have direct metallic contact with the measuring point and have firm contact with the surface of the pipe. Where temperatures under 200 °C are expected, a thermal compound can be used to optimise the heat transfer between contact bulb and pipe. Insulation must be applied at the mounting point to avoid error due to heat loss. This insulation must have sufficient temperature resistance and is not included in the scope of delivery.

Pipe clamp mounting

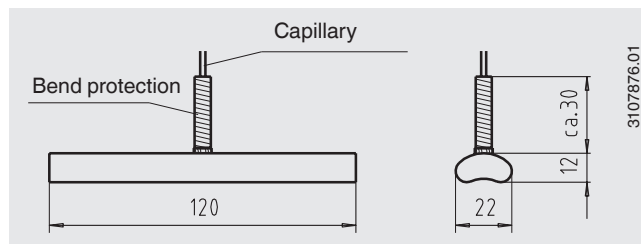
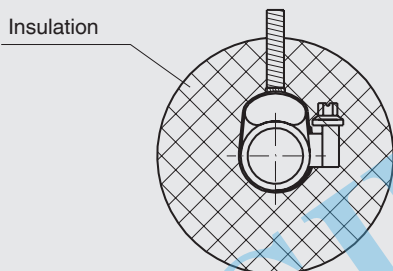

■ Mounting on tanks

The geometry of the contact bulb has been designed for tanks with an external radius up to 80 mm. If the mounting point of the contact bulb on the tank has an external radius greater than 80 mm, we recommend the use of an intermediate piece designed for the respective tank diameter, made of a material with good thermal conductivity. The contact bulb can be fastened to the tank by means of an angle bracket with clamping screws, or any similar method. The contact bulb should have direct metallic contact with the measuring point and have firm contact with the surface of the tank.

A thermal compound can be used to optimise the heat transfer between contact bulb and tank, if temperatures under 200 °C are expected. Insulation must be applied at the mounting point to avoid error due to heat loss. This insulation must have sufficient temperature resistance and is not included in the scope of delivery.

Angle bracket mounting

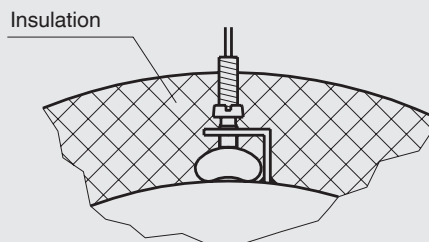

Thermowell

In principle, the operation of a mechanical thermometer is possible without a thermowell with low process-side loading (low pressure, low viscosity and low flow velocities).

However, in order to enable exchanging the thermometer during operation (e.g. instrument replacement or calibration) and to ensure a better protection of the measuring instrument and also the plant and the environment, it is advisable to use a thermowell from the extensive WIKA thermowell portfolio.

For further information on the wake frequency calculation, see Technical information IN 00.15.

Ordering information

Model / Nominal size / Type of contact and switching function / Scale range / Connection design / Process connection / Length l_1 / Capillary length l_F / Options

© 06/2009 WIKA Alexander Wiegand SE & Co. KG, all rights reserved.
The specifications given in this document represent the state of engineering at the time of publishing.
We reserve the right to make modifications to the specifications and materials.

